

SENTRY TECHNICAL MANUAL

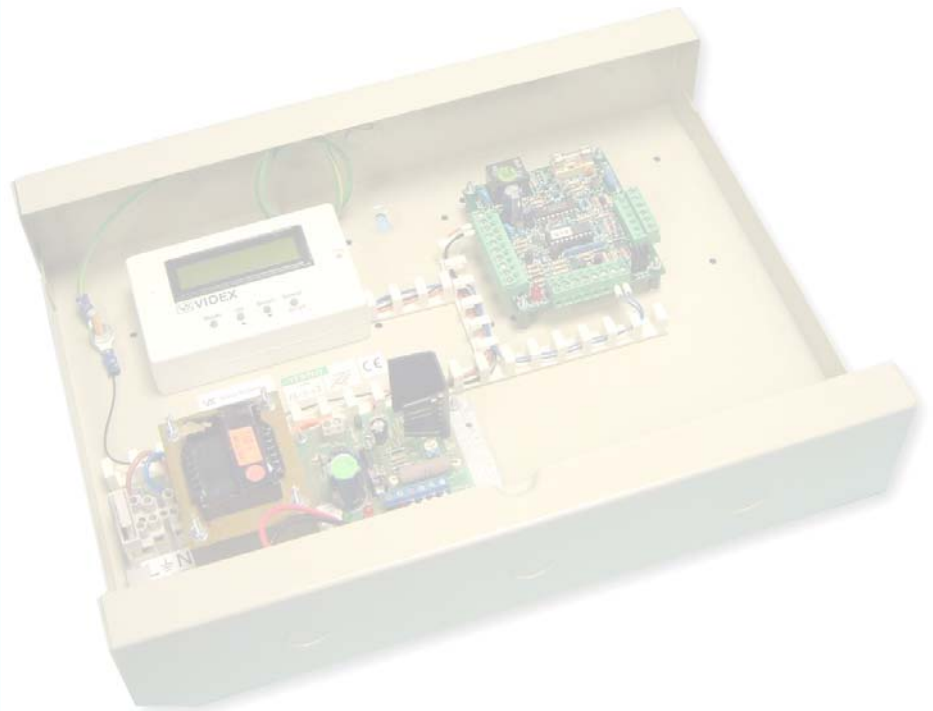

TECHNICAL MANUAL
EDITION 1.6

VIDEX
The Power to Secure



CONTENTS

	PAGE
Manual Introduction	2
System Introduction	2
System Components	2 – 12
System Operation	13
Vandal Resistant Panel layout and sizes	14
Installation	15
Block Diagrams	16
Cable Size tables	17
Testing the installation	18
Telephone Connections Compatibility Chart	19
Accessories Connection Guide	20
Standard wiring diagram	21
Isolated system wiring diagram	22
800 Series door panel wiring diagram	23
Video system wiring diagram	24 – 25
Apartment station system wiring diagram	26
Art136 amplifier wiring diagram	27
Trouble Shooting Guide	28 - 29

MANUAL INTRODUCTION

The information in this manual is intended as an installation and commissioning guide for the Sentry system. This manual should be read carefully before the installation commences. Any damage caused to the equipment due to faulty installations where the information in this manual has not been followed is not the responsibility of Videx Security Ltd.

VIDEX run free training courses for engineers who have not installed the sentry system before. Technical help is also available on 0191 224 3174 during office hours or via e-mail tech@videx-security.com.

SYSTEM INTRODUCTION

The Sentry system is primarily a single entrance audio or audio/video system which is capable of being expanded to multiple entrances with additional equipment. The system has no limit on the number of apartments for which it can control although we suggest using this system on small to medium sized installation of no more than 20 apartments.

The system benefits from advanced features such as full privacy of speech, fully privacy of lock release, adjustable calling time, speech time and door open time and the facilities for both push to exit button and tradesman button. There are many optional extras available for the system including full line card isolation, door monitoring and access control (coded, proximity, Bio). A range of options are also available for the apartments including a range of telephones with varying facilities, videophones, extension sounders and strobes.

SYSTEM COMPONENTS

A standard audio system will comprise of a door panel, control cabinet and audio telephones. A standard video system will comprise of a door panel, control cabinet, video splitters and videophones. The individual parts are described below.

DOOR PANELS

Door panels from the 800 Series (Using the 837 amplifier), 4000 Series (Using the 4837 or 4832 amplifier) and vandal resistant (Using the 437 or 537 amplifier) range can be used on the Sentry system.

Art.437 or 537 Amplifier + Connector PCB

Connection	Function
1	Receive speech from apartment
2	Transmit speech to apartment
3	Switched +12Vdc input
4	0V (Ground)
CB	Button common connection
1	Push button 1 output
2	Push button 2 output
...	
10	Push button 10 output

Art.837 Amplifier connections

Connection	Function
2	Transmit speech to apartment
~	13Vac input for name plate lights
3	Switched +12Vdc input
1	Receive speech from apartment
4	0V (Ground)
~	0V input for name plate lights
X	Not Used
P2	Push button 2 output
P1	Push button 1 output
C	Button common connection

Art.4837 Amplifier connection

Connection	Function
C	Buttons common connection
C1	Calltone out (Not used on Sentry)
P1	Push button 1 output
P2	Push button 2 output
S1	Common relay (Not used on Sentry)
S	Normally Open Relay (Not used)
RL	0V relay trigger (Not used on Sentry)
-	0V Ground
1	Receive speech from apartment
+	Switched +12Vdc input
2	Transmit speech to apartment
P3	Push button 3 output
P4	Push button 4 output

Art.4832 Amplifier connection

Connection	Function
I	Camera power input (14-20Vdc)
F1	Camera 0V
M/V2	Video Screen or Video sync+
V/V1	Video centre core or Video sync-
C	Buttons common connection
C1	Calltone out (Not used on Sentry)
P1	Push button 1 output
S1	Common relay (Not used on Sentry)
S	Normally Open Relay (Not used)
RL	0V relay trigger (Not used on Sentry)
-	0V Ground
1	Receive speech from apartment
+	Switched +12Vdc input
2	Transmit speech to apartment
P3	Push button 3 output

ART.136 AMPLIFIER (Software version 136-12 or later)

Connection	Function
1	Receive speech from apartment
2	Transmit speech to apartment
+ (3)	+12Vdc input (Amplifier connection 3 on the Sentry PCB)
- (4)	0V (Ground) (Amplifier connection 4 on the Sentry PCB)
5	Link to terminal – when used on Sentry system
T	Electronic call tone output to common side of call buttons (NOT USED ON SENTRY SYSTEM)
-	Link to terminal 5 when used on Sentry system
PTE	push to exit button to trigger door release relay (NOT USED ON SENTRY SYSTEM)
C	Common connection of dry contact relay (NOT USED ON SENTRY SYSTEM)
NC	Normally closed connection of dry contact relay (NOT USED ON SENTRY SYSTEM)
NO	Normally open connection of dry contact relay (NOT USED ON SENTRY SYSTEM)
D+	External link to door open (+12V side) LED.
D-	External link to door open (0V side) LED.
BSY	Busy signal (NOT USED ON SENTRY SYSTEM)
SL	Switched 0V output to switch on video PSU. (NOT USED ON SENTRY SYSTEM)
F1	Switched 0V output to switch on camera. (NOT USED ON SENTRY SYSTEM)

Dip-switches and jumper setting on Art.136 amplifier

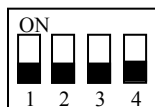

When using the Art.136 amplifier with the Sentry system, all dip-switches must be off

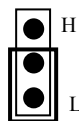

Position H	High volume reassurance tones
Position L	Low Volume reassurance tones
No Jumper	No reassurance tones

This jumper will not adjust the reassurance tone on the Sentry system



IMPORTANT NOTE (Art.136 Amplifier only): A 680R resistor needs to be fitted across terminals 1 & 3 of the amplifier and a wire link across terminals 5 & - of the amplifier.

Speech volume adjustments are carried out at the door panel using a small trimmer driver.



Adjustment for speech volume level at the door station



Adjustment for speech volume at the apartment

Please see block diagram on page 16 for cable requirements

CONTROL CABINET

The control cabinet consists of three primary components plus optional extra components such as line card isolation, door monitoring etc. The three primary components are the Sentry control PCB, power supply unit and time clock.

SENTRY PCB

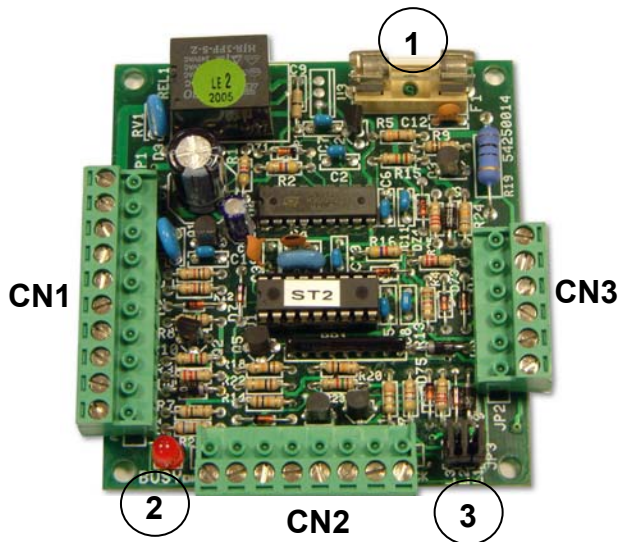

- 1 Call tone line protection fuse 315mA
- 2 Call in progress LED
- 3 JP3 Timer jumpers for call time, speech time and relay time

CONNECTIONS

CON	Terminal	Function
CN1	+12	12Vdc Input power
	GND	0V (Ground)
	NO	Normally open relay
	CO	Common relay
	NC	Normally closed relay
	CB	Call button common
	4	0V to amplifier
	3	Switched +12 to amp
	1	Transmit speech to amp
	2	Receive speech from amp
CN2	ENG-LO	Engaged signal
	ENG-LA	Busy lamp connection
	FIREMAN SWITCH	Fireman switch input Triggers relay for set time
	TRADE BUTTON	Trade button input
	TIME CLOCK	Time clock input
	CN3	+12
	7	0V to telephones
	4	Call tone output
	2	Transmit speech to phone
	1	Receive speech from phone
	5	Lock release trigger

The Sentry PCB includes three jumpers to select calling time, speech time and door open time:-

	JP3	LINK FITTED	LINK REMOVED
CALL TONE LENGTH	L1	15 Seconds (3 rings)	25 Seconds (6 Rings)
SPEAK TIME	L2	30 Seconds	90 Seconds
LOCK OPEN TIME	L3	5 Seconds	10 Seconds

POWER SUPPLY

A control cabinet for an audio system will contain a 13.8Vdc PSU with battery back up facility. The standard power supply is rated at 1 Amp. (Care should be taken to calculate the current consumption of the lock release as it may be necessary to upgrade this power supply to either a 2 Amp or even a 3 Amp). Video control cabinets will have an additional PSU rated at 20Vdc 1 Amp surge or 800mA continuous. This additional power supply is described below and is used to power the videophones and the camera.

Art. 893N

20Vdc 800mA continuous 1A surge PSU. This power supply only has an output when either a 0V is applied to -C or when a voltage is applied to +C. At all other times the + output is switched off.



Connection	Function
230V~ 0	Mains voltage input
+	Switched 20Vdc output (Triggered by -C or +C)
-	0V
-C	0V trigger input (From 4V to 0V)
+C	+ volts trigger input (From 8V up to 30V)
D+	+20Vdc output via diode

Art.701

BST/GMT digital time clock. This time clock operates from a 12Vac or dc power supply. The output is a dry contact relay. When used with the Sentry control system the relay is used to short the time clock inputs on the sentry PCB which will in turn enable the trade button input to accept a short from a trade button. This will then energise the lock relay on the Sentry PCB.



Connection	Function
+	12Vac or dc voltage input
-	0V
TR	Not used with Sentry system
C	Common connection on relay
NO	Normally open connection on relay
NC	Normally closed connection on relay

For more information see time clock instruction sheet

OPTIONAL ISOLATION PCB

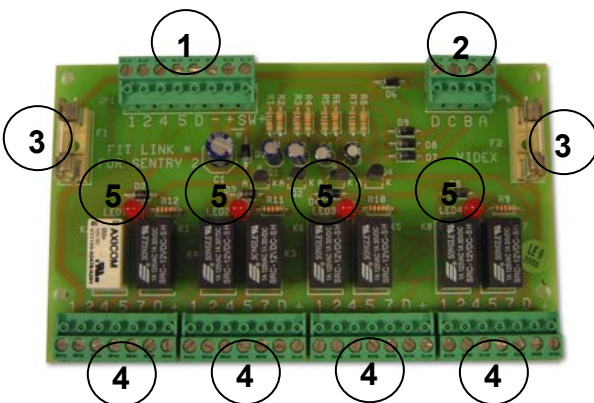

An isolation card will prevent a fault in a single apartment affecting the rest of the system. The isolation card has four channels (One card required for every four apartments) and can be mounted in the main control cabinet or in riser boxes.

Operation:

The isolation card will trigger an output when it receives a positive voltage on either A, B, C or D. The output will stay triggered as long as the SW+ terminal has 12 volts present. Once the 12V is removed from the SW+ terminal the output will switch back into isolated mode. The inputs A-D are from the call buttons at the door panel and the SW+ is switched by the Sentry PCB (Terminal 3 of the amp). Four LED's on the PCB indicate when an output is live.

- 1 Power and phone commons from Sentry PCB
- 2 Select lines from call buttons
- 3 Call tone & +12V to phones fuse
- 4 Phone connections to apartment
- 5 Output live LED

INTERCOM 3 PCB



The intercom 3 apartment station interface PCB is required whenever the 500, 500M or 500ST apartment station are used. This PCB converts the duplex speech into simplex speech and controls the switching of the apartment station

- 1 CN1 Connections in from Sentry PCB
- 2 CN2 Connections out to apartment station
- 3 Volume adjust

CON	Terminal	Function
CN1	+12V	+12Vdc In
	Gnd	Ground
	3	Switched 12Vdc
	4	Calltone
	2	Receive Speech
	1	Transmit Speech
	5	Lock Trigger
CN2	1	Lock button
	6	Talk button
	2	Switched 12Vdc
	3	Speaker
	5	Ground
	+12V	+12Vdc Out

NOTE

In the event of the speech needing to be adjusted to eliminate feedback or to increase the speech volume to an acceptable level the following two options are available :-

Option 1. The speech can be adjusted at the door panel amplifier by adjusting the two volume controls (One for transmitting to the apartment and one for receiving from the apartment).

Option 2. There is also a volume POT [VR1] on the intercom 3 PCB. This will adjust both directions of speech at the same time and is only intended for situations when the volume cannot be adjusted sufficiently at the door panel. (Note: This will also adjust the call tone volume both at the door and at the apartment station).

AUDIO TELEPHONES

Art.3121

The Art.3121 includes a three position call tone volume control, lock release push button and spare dry contact push to make button for other services.



CONNECTIONS:-

	Function
1	Transmit speech to the door panel
2	Receive speech from the door panel
T	Call tone in from Sentry PCB
P	Switch 0V lock trigger command
-	0V
C	Select line (Switches on telephone)
8	Dry contact switch
9	

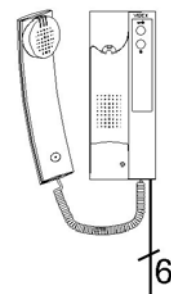

Art.3123

The Art.3123 includes a three position call tone volume control, lock release push button and spare dry contact push to make button for other services. Additionally it includes a slide mute switch with LED to turn the phone off when the tenant does not want to be disturbed.



CONNECTIONS:-

	Function
1	Transmit speech to the door panel
2	Receive speech from the door panel
T	Call tone in from Sentry PCB
P	Switch 0V lock trigger command
-	Not Used
C	Select line (Switches on telephone)
8	Dry contact switch
9	
SWITCH PCB	
-	0V
+/~	+12V for mute LED

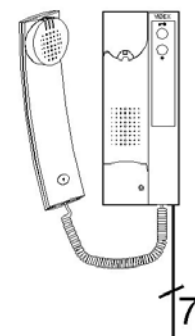

Art.3125

The Art.3125 includes a three position call tone volume control and large lock release push button. Additionally it includes a push on push off mute switch with status LED and a door open LED.



CONNECTIONS:-

	Function
1	Transmit speech to the door panel
2	Receive speech from the door panel
T	Call tone in from Sentry PCB
P	Switch 0V lock trigger command
-	0V
C	Select line (Switches on telephone)
D	Switched +12 in for door open LED
+12	+12V for mute circuit

Art.3126

The Art.3126 includes a three position call tone volume control and large lock release push button. Additionally it includes a push on push off timed mute switch with status LED and a door open LED.

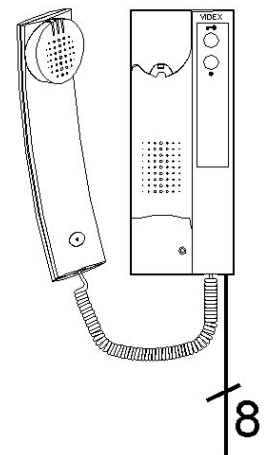

CONNECTIONS:-

	Function
1	Transmit speech to the door panel
2	Receive speech from the door panel
T	Call tone in from Sentry PCB
P	Switch 0V lock trigger command
-	0V
C	Select line (Switches on telephone)
D	Switched +12 in for door open LED
+12	+12V for mute circuit

JUMPER SETTINGS:-

FIVE SETTINGS ARE AVAILABLE FOR THE PRIVACY TIME	
Jumper in position A	15 Minutes
Jumper in position B	30 Minutes
Jumper in position C	2 Hours
Jumper in position D	4 Hours
Jumper in position E	8 Hours

SET THE PRIVACY LED TO FLASH OR ON CONSTANT	
Jumper in position FL	Flash the privacy LED
Jumper in position FX	LED on constant

VIDEOPHONES

901D

The Art.901D (901D/C for colour) includes a lock release push button and a dry contact push to make spare push button for other services.

CONNECTIONS:-

	Function
1	Transmit speech to the door panel
2	Receive speech from the door panel
T	Call tone in from Sentry PCB
P	Switch 0V lock trigger command
-	0V
C	Select line (Switches on telephone)
V	Centre core of coax
M	Screen of coax
M	0V
+12	+12V out to power video splitter Art.894
+20	Switched +20V in to power videophone

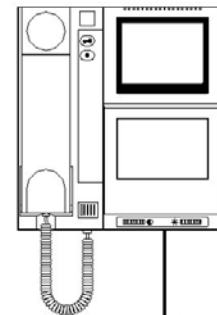

9 + Coax

Art.3313

The Art.3313 (3413 for colour) includes a lock release push button and two dry contact push to make spare push buttons for other services. An Art.3980 back plate is required with this videophone.

CONNECTIONS:-

	Function
1	+12V out to power video splitter
2	Not used
3	Spare button
4	+20V power input
5	Door release command
6	Transmit speech to door panel
7	Receive speech from door panel
8	0V (Ground)
9	Not used
10	Local call tone input
11	Coax centre core or non-coax sync-
12	Coax Screen or non-coax Sync+
13	Switched +12 for door open LED
14	Select input to switch on videophone
15	Call tone input from Sentry PCB
16	Common of spare buttons
17	Spare button
18	+12V to power videophone privacy

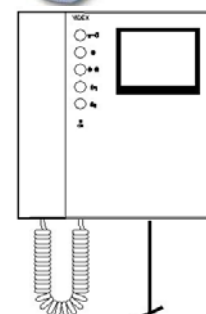

11 + Coax

DIP SWITCH SETTINGS

8 Way dip switch (Switches 1 – 5)

Mute Duration time					
Time	1	2	3	4	5
15 Minutes	ON	OFF	OFF	OFF	OFF
30 Minutes	OFF	ON	OFF	OFF	OFF
2 Hours	OFF	OFF	ON	OFF	OFF
4 Hours	OFF	OFF	OFF	ON	OFF
8 Hours	OFF	OFF	OFF	OFF	ON

8 Way dip switch (Switch 6)

Mute LED	
Switch	6
Fixed	OFF
Flashing	ON

8 Way dip switch (Switches 7 & 8)

°° Button Operation		
Switch	7	8
Camera recall	ON	OFF
Dry contact	OFF	ON

4 Way Dip Switch (Switches 1 & 2)

S Button Operation		
Switch	1	2
Camera recall	ON	OFF
Dry contact	OFF	ON

4 Way Dip Switch (Switches 3 & 4)

VIDEO MODE		
Switch	3	4
Coax	ON	ON
Non-Coax	OFF	OFF

3 Way Dip Switch

VIDEO MODE continued			
Switch	1	2	3
Coax	OFF	OFF	OFF
Non-Coax	ON	ON	ON

APARTMENT STATIONS

500

The model 500 apartment station includes a push to talk button, door release button and slide mute switch. The Intercom 3 PCB must be used when using this apartment station.

Connections:

	Function
4	Select line from call button
2	Switched +12V to activate
6	Talk Button
1	Lock release button
3	Audio
5	Ground

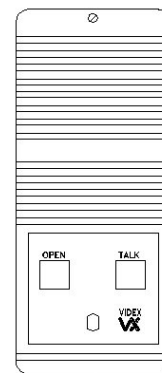

16

500M

The model 500M apartment station includes a push to talk button, door release button and push mute switch with LED and door open LED. The Intercom 3 PCB must be used when using this apartment station.

Connections:

	Function
4	Select line from call button
2	Switched +12V to activate
6	Talk Button
1	Lock release button
3	Audio
5	Ground
+	12Vdc to power mute circuit
D	Switch 0V to trigger door open LED

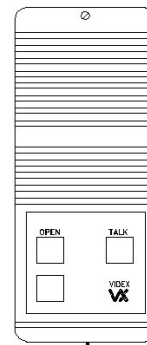

18



PRIVACY LED FIXED OR FLASHING



FIXED



FLASHING

500ST

The model 500ST apartment station includes a push to talk button, door release button and timed push mute switch with LED and a door open LED. The Intercom 3 PCB must be used when using this apartment station.

Connections:

	Function
4	Select line from call button
2	Switched +12V to activate
6	Talk Button
1	Lock release button
3	Audio
5	Ground
+	12Vdc to power mute circuit
D	Switch 0V to trigger door open LED

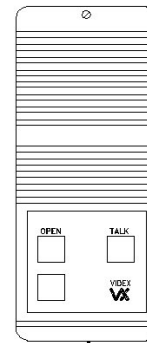

18



PRIVACY LED FIXED OR FLASHING



FIXED



FLASHING

PRIVACY TIMES

TIME	15 MIN	2 HOUR	4 HOUR	8 HOUR
SETTING				

ACCESSORIES

Art. 512A

Extension sounder for an apartment. This sounder can be wall mounted and will ring whenever the telephone it is connected to rings.



Connections	
4	Call tone input
-	0V (Ground)

ES/1

Timed strobe unit for the hard of hearing or noisy environments. The strobe will flash when a call is received and will continue flashing for an adjustable time period or until the reset button is pressed.



Connections	
POWER	12V AC or DC input
I/P	+ trigger
+O/P	12Vdc output
GND	Ground
RESET	Switched negative reset
NC	Normally closed relay connection
CO	Common relay connection
NO	Normally open relay connection

SYSTEM OPERATION

CALL: A call will be activated by a visitor pressing the desired flat number on the door panel. A timed call tone will be heard at the occupants telephone (This will last for the time set via jumper L1 or until the call is answered). A reassurance call tone will also be heard at the door panel to indicate the system has been activated. If the occupant does not answer the telephone, the call will clear down. If the occupant does answer the telephone, the call tone will stop as soon as the handset is lifted. A two way conversation will then take place (This will time out after the preset time set via jumper L2). If the occupant does not want to let the caller into the building, the handset would be placed back on its cradle and the call will clear down. If the occupier does want to let the caller into the building, the lock button would be pressed and the door would open for the preset time. The lock button will not work at any other time (A call must be placed to the handset and handset must be answered before the lock button will work). Please note: This system has full privacy of speech which means the speech lines will appear dead until a call is placed to that apartment

TRADE: The trade button only works when the time clock is active (A short across the time clock terminals on the Sentry PCB). At this time when the trade button is pressed the door will open for the preset time (Set via jumper L3).

FIREMAN SWITCH/EXIT BUTTON: The fireman switch will work at all times. When this is activated the door will open for the preset time (Set via jumper L3).

BUSY LIGHT: A busy light would be used when more than one sentry PCB is being used to control multiple door systems. The busy light will illuminate when a call is activated at any door panel. (To use several sentry PCB's together, simply connect the phone commons from the PCB's together and also connect the engaged lines ENG-LO together).

VANDAL RESISTANT PANEL LAYOUT AND SIZES

Standard audio panels

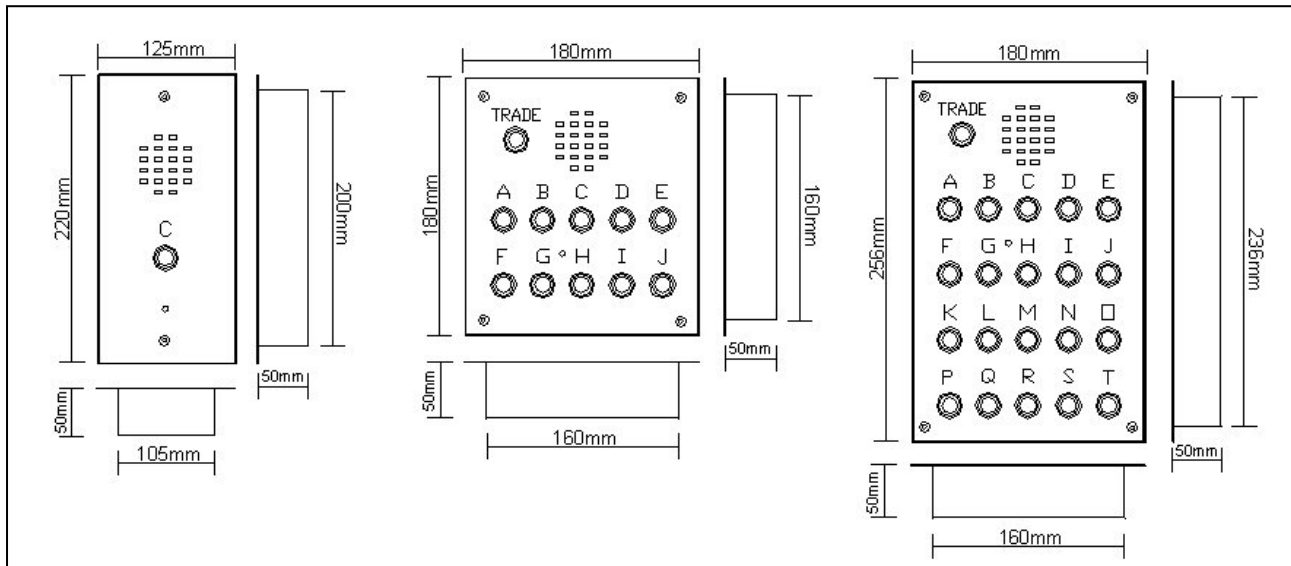

- 1 BUTTON = C
- 2 BUTTON = B, D (Note: Also available in 125mm 220mm panel style)
- 3 BUTTON = A, C, E
- 4 BUTTON = B, D, G, I
- 5 BUTTON = A, C, E, G, I
- 6 BUTTON = A, C, E, F, H, J
- 7 BUTTON = A, B, C, D, E, G, I
- 8 BUTTON = A, B, C, D, E, G, H, I
- 9 BUTTON = A, B, C, D, E, F, G, I, J
- 10 BUTTON = A, B, C, D, E, F, G, H, I, J
- 11 BUTTON = A, C, E, F, H, J, K, M, O, Q, S
- 12 BUTTON = A, C, E, F, H, J, K, M, O, P, R, T
- 13 BUTTON = A, C, E, F, H, J, K, M, O, P, Q, S, T
- 14 BUTTON = A, C, E, F, H, J, K, M, O, P, Q, R, S, T
- 15 BUTTON = A, B, C, D, E, F, G, H, I, J, K, L, M, N, O
- 16 BUTTON = A, B, C, D, E, F, G, H, I, J, K, L, M, N, O, R
- 17 BUTTON = A, B, C, D, E, F, G, H, I, J, K, L, M, N, O, Q, S
- 18 BUTTON = A, B, C, D, E, F, G, H, I, J, K, L, M, N, O, P, R, T
- 19 BUTTON = A, B, C, D, E, F, G, H, I, J, K, L, M, N, O, P, Q, S, T
- 20 BUTTON = A, B, C, D, E, F, G, H, I, J, K, L, M, N, O, P, Q, R, S, T

Other standard panel sizes:-

- 1 – 10 button with video [180mm (W) x 256mm (H) x 50mm (D)]
- 11 – 20 button + video [200mm (W) x 350mm (H) x 50mm (D)]

- 1 – 10 button + proximity [180mm (W) x 256mm (H) x 50mm (D)]
- 11 – 20 button + proximity [200mm (W) x 350mm (H) x 50mm (D)]

- 1 – 10 button + codelock [180mm (W) x 256mm (H) x 50mm (D)]
- 11 – 20 button + codelock [200mm (W) x 420mm (H) x 50mm (D)]

- 1 – 10 button + video & proximity [200mm (W) x 350mm (H) x 50mm (D)]
- 1 – 10 button + video & codelock [200mm (W) x 420mm (H) x 50mm (D)]

INSTALLATION

The wiring diagrams towards the back of this manual should be followed carefully. Heavy duty conductors on wiring diagrams are shown heavily outlined, These wires should be doubled up.

- Check that all components are free from damage before installing (Do not proceed with installation in the event of damage).
- Keep all packaging away from children.
- Do not obstruct the ventilation openings or slots on any of the devices.
- All connections to mains voltages must be made to the current national standards (IEE Wiring regulations)
- Install an appropriate fused spur or isolation switch to isolate the mains.
- Isolate the mains before carrying out any maintenance work on the system.
- All intercom and access control cables must be routed separately from the mains.

Lock release protection : A diode must be fitted across the terminals on the lock release to suppress back EMF voltages. The diagram below shows the polarity of the diode when fitted to the release.

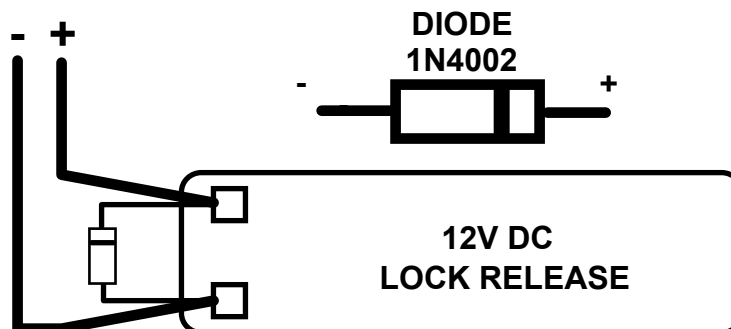

Cable size and type : When running cables for any intercom system, these cables must be installed separately from the mains cables. All multi pair cables should be to CW1308 specification. (0.5mm twisted pair telephone cable). Max resistance = 10 Ohm.
 Lock release wires should be doubled up. Max resistance = 3 Ohm
 The cables sizes above can be used for distances up to 100m. On distances above 100m the cable sizes should be increased to keep the overall resistance of the cable below the RESISTANCES indicated above.

AUDIO SYSTEM BLOCK DIAGRAM

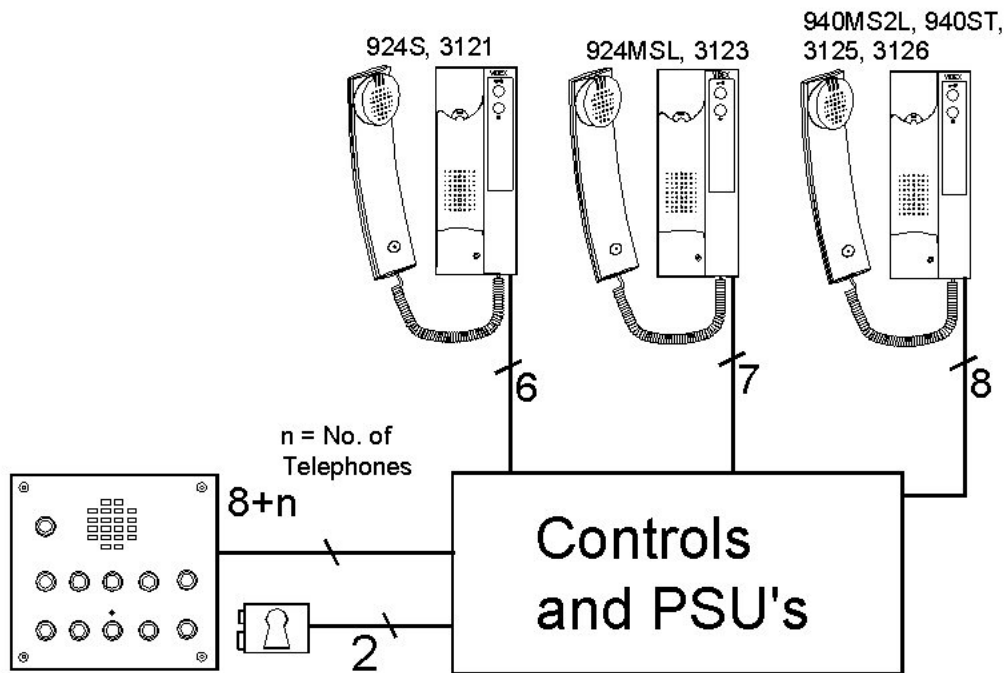

Note: Additional cores will be required for auxiliary devices such as push to exit buttons, fireman switches, proximity access control etc.

VIDEO SYSTEM BLOCK DIAGRAM

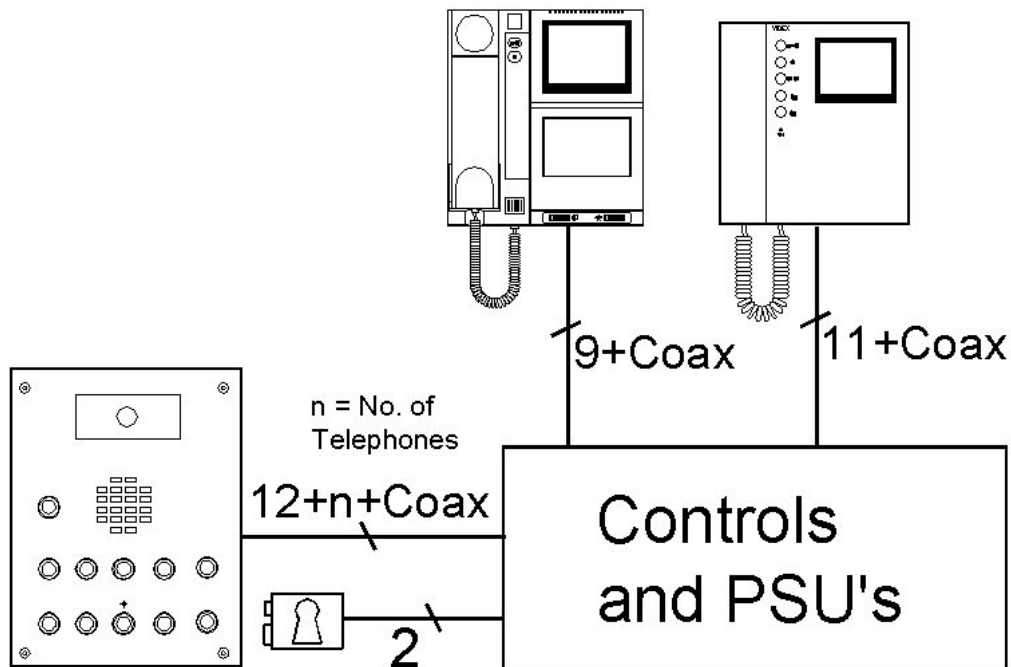

Note: Additional cores may be required for auxiliary items such as push to exit buttons, fireman switch proximity access control etc..

The block diagram above shows all videophones coming back to one point with all the video distributors at that point. It is also possible to spread the video distributors around the building (Please see wiring diagrams for more information).

Connections from the door panel to the control cabinet.

(NOTE: Additional connections may be needed for fireman switches keypads, proximity etc)

Connections	50m	100m	200m	300m	400m
Amp 1	0.25mm ²	0.35mm ²	0.5mm ²	0.75mm ²	1.0mm ²
Amp 2	0.25mm ²	0.35mm ²	0.5mm ²	0.75mm ²	1.0mm ²
Amp 3	0.25mm ²	0.35mm ²	0.5mm ²	0.75mm ²	1.0mm ²
Amp 4	0.25mm ²	0.35mm ²	0.5mm ²	0.75mm ²	1.0mm ²
CB	0.25mm ²	0.35mm ²	0.5mm ²	0.75mm ²	1.0mm ²
Selects 1-n	0.25mm ²	0.35mm ²	0.5mm ²	0.75mm ²	1.0mm ²
Trade	0.25mm ²	0.35mm ²	0.5mm ²	0.75mm ²	1.0mm ²
Trade	0.25mm ²	0.35mm ²	0.5mm ²	0.75mm ²	1.0mm ²
Lock	0.5mm ²	0.75mm ²	1.5mm ²	2.0mm ²	2.5mm ²
Lock	0.5mm ²	0.75mm ²	1.5mm ²	2.0mm ²	2.5mm ²
V*	Standard quality	Medium quality	Good quality	Good quality	High quality
M*	75Ω Coax cable	75Ω Coax cable	75Ω Coax cable	75Ω Coax cable	75Ω Coax cable
I (+20)*	0.35mm ²	0.5mm ²	1.0mm ²	1.5mm ²	2.0mm ²
F1 (Vid 0V)*	0.35mm ²	0.5mm ²	0.75mm ²	1.0mm ²	1.5mm ²
SB (+12V)*	0.25mm ²	0.35mm ²	0.5mm ²	0.75mm ²	1.0mm ²

* These lines are only required on video systems.

V is the centre core of the coax and M is the screen.

For best performance, keep the distance between the door panel and the control cabinet to a minimum.

Connections from the control cabinet to the apartment.

Connections	50m	100m	200m	300m	400m
1	0.35mm ²	0.35mm ²	0.5mm ²	0.75mm ²	1.0mm ²
2	0.35mm ²	0.35mm ²	0.5mm ²	0.75mm ²	1.0mm ²
-	0.35mm ²	0.35mm ²	0.5mm ²	0.75mm ²	1.0mm ²
4(T)	0.35mm ²	0.35mm ²	0.5mm ²	0.75mm ²	1.0mm ²
5(P)	0.35mm ²	0.35mm ²	0.5mm ²	0.75mm ²	1.0mm ²
6(C)	0.35mm ²	0.35mm ²	0.5mm ²	0.75mm ²	1.0mm ²
D*	0.35mm ²	0.35mm ²	0.5mm ²	0.75mm ²	1.0mm ²
+12*	0.35mm ²	0.35mm ²	0.5mm ²	0.75mm ²	1.0mm ²
V(11)**	Standard quality	Medium quality	Good quality	Good quality	High quality
M(12)**	75Ω Coax cable	75Ω Coax cable	75Ω Coax cable	75Ω Coax cable	75Ω Coax cable
+20**	0.35mm ²	0.5mm ²	1.0mm ²	1.5mm ²	2.0mm ²
Vid Gnd**	0.35mm ²	0.5mm ²	1.0mm ²	1.5mm ²	2.0mm ²
+12OUT**	0.35mm ²	0.5mm ²	N/A	N/A	N/A
T(16)**	0.35mm ²	0.35mm ²	0.5mm ²	0.75mm ²	1.0mm ²
1T(17)**	0.35mm ²	0.35mm ²	0.5mm ²	0.75mm ²	1.0mm ²
2T(18)**	0.35mm ²	0.35mm ²	0.5mm ²	0.75mm ²	1.0mm ²

* Only required on phones with privacy and/or door monitoring.

** Only required on videophones

V is the centre core of the coax and M is the screen.

Safety Note : The earth wire from the cabinet lid should be connected to the cabinet base and then to the earth connection in the building. This should be checked for continuity.

An earth connection should also be fitted to the door panel stainless steel facia using one of the studs provided.

TESTING THE INSTALLATION

- Check all the connections have been made correctly and then power up the system.
- Call all the apartments in turn. Check for call tone to the apartment, speech in both directions and lock release.
- If the volume of speech needs to be adjusted, this can be done by adjusting the presets on the rear of the amplifier at the door panel as shown on page 3.
- If the call tone volume needs adjusting this can be done at each handset (Three position slid switch on the telephone).
- Check the fireman switch (If fitted).
- Set the time clock on/off times (Use the instruction supplied with the time clock). Check the trade button only works when the time clock is on.

TELEPHONE CONNECTIONS COMPATIBILITY CHART

AUDIO TELEPHONES

MODEL	Transmit Speech	Receive Speech	Call Tone	Lock Release	Ground	Trigger	+12V	Door Monitor
3121	1	2	T	P	-	C	N/A	N/A
3123	1	2	T	P	-	C	+	N/A
3125	1	2	T	P	-	C	+12	D
3126	1	2	T	P	-	C	+12	D
924S	1	2	T	P	-	C	N/A	N/A
924MSL	1	2	T	P	-	C	+	N/A
940MS2L	1	2	T	P	-	C	+12	D
940ST	1	2	T	P	-	C	+12	D
524S	1	2	4H or 4L	5	7	6	N/A	N/A
524MS	1	2	4H or 4L	5	7M	6	N/A	N/A
524MSL	1	2	4H or 4L	5	7M	6	+	N/A
526ST	1	2	T	P	-	C	+	D
500MM	1A	2A	T/4	NO/P	GND	C/6	+12	N/A

VIDEOPHONES

MODEL	TX SPEECH	RX SPEECH	CALL TONE	LOCK RELEASE	AUDIO GND	Trig	VIDEO GND	+ IN VIDEO	VID SIG	+12 IN	+12 Out	Door Mon.
901D	1	2	T	P	-	C	M	+20	V&M	N/A	+12	N/A
3313	6	7	15	5	8	14	8	4	11&12	18	1	13

APARTMENT STATIONS

MODEL	SELECT	SWITCHED 12V	TALK BUTTON	LOCK BUTTON	AUDIO	GND	+12V SUPPLY	DOOR MONITOR
500	4	2	6	1	3	5	N/A	N/A
500M	4	2	6	1	3	5	+	D
500ST	4	2	6	1	3	5	+	D

ACCESSORIES CONNECTION GUIDE

BUSY LAMP

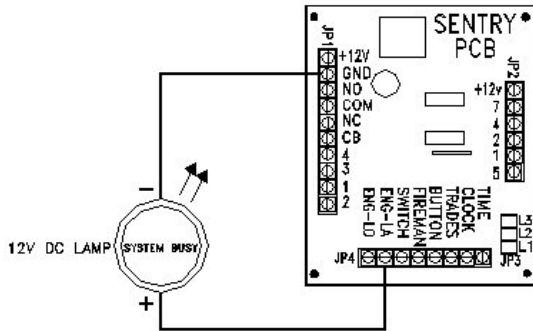

DURING A CALL THE BUSY LAMP WILL ILLUMINATE TO INDICATE A CALL IS IN PROGRESS

PUSH TO EXIT (PUSH TO MAKE)

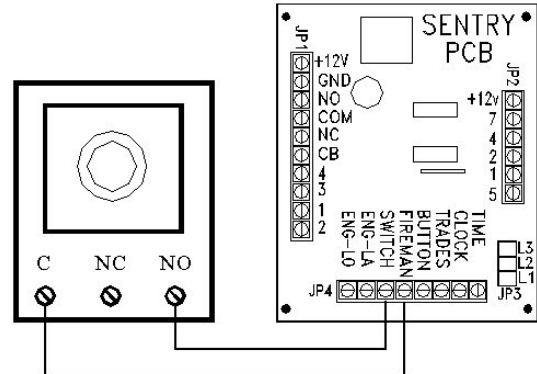

PUSHING THIS BUTTON AT ANY TIME WILL RELEASE LOCK RELEASE

FAIL SAFE LOCK RELEASE

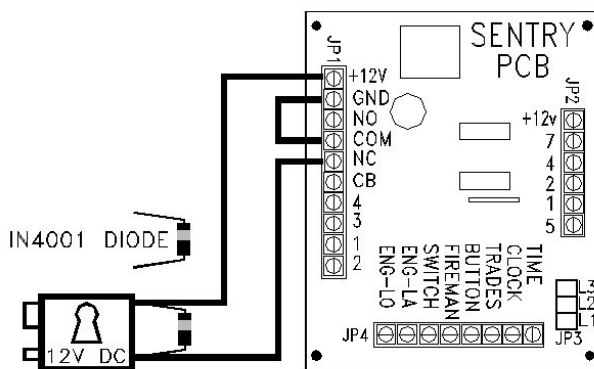

EMERGENCY FIREMAN SWITCH

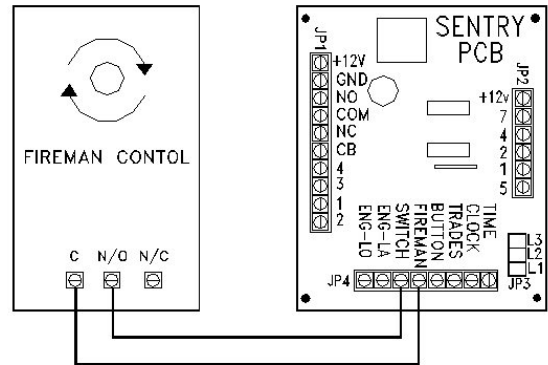

TURNING THIS KEY DURING AN EMERGENCY WILL RELEASE THE LOCK RELEASE AT ANY TIME

CONNECTING THE 512A EXTENSION SPEAKER

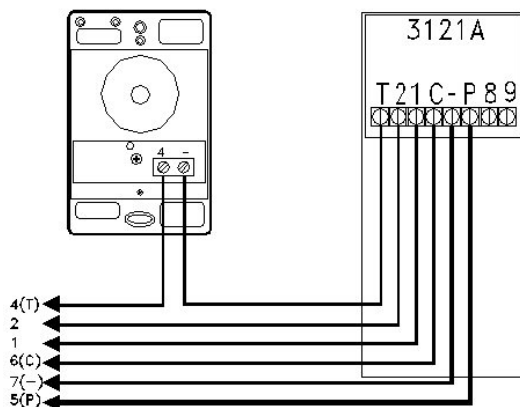

DURING A CALL THE EXTENSION SPEAKER WILL RING

EXTENSION STROBE

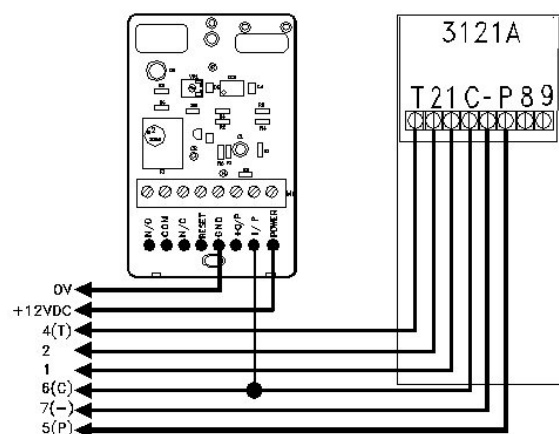

DURING A CALL THE STROBE LIGHT WILL FLASH

WIRING DIAGRAM

This diagram shows a single entrance vandal resistant door panel connected to multiple apartments. The lock release shown is fail safe and a break glass is connected in line. We recommend bringing all telephones back to one point (i.e. control cabinet) on this type of installation.

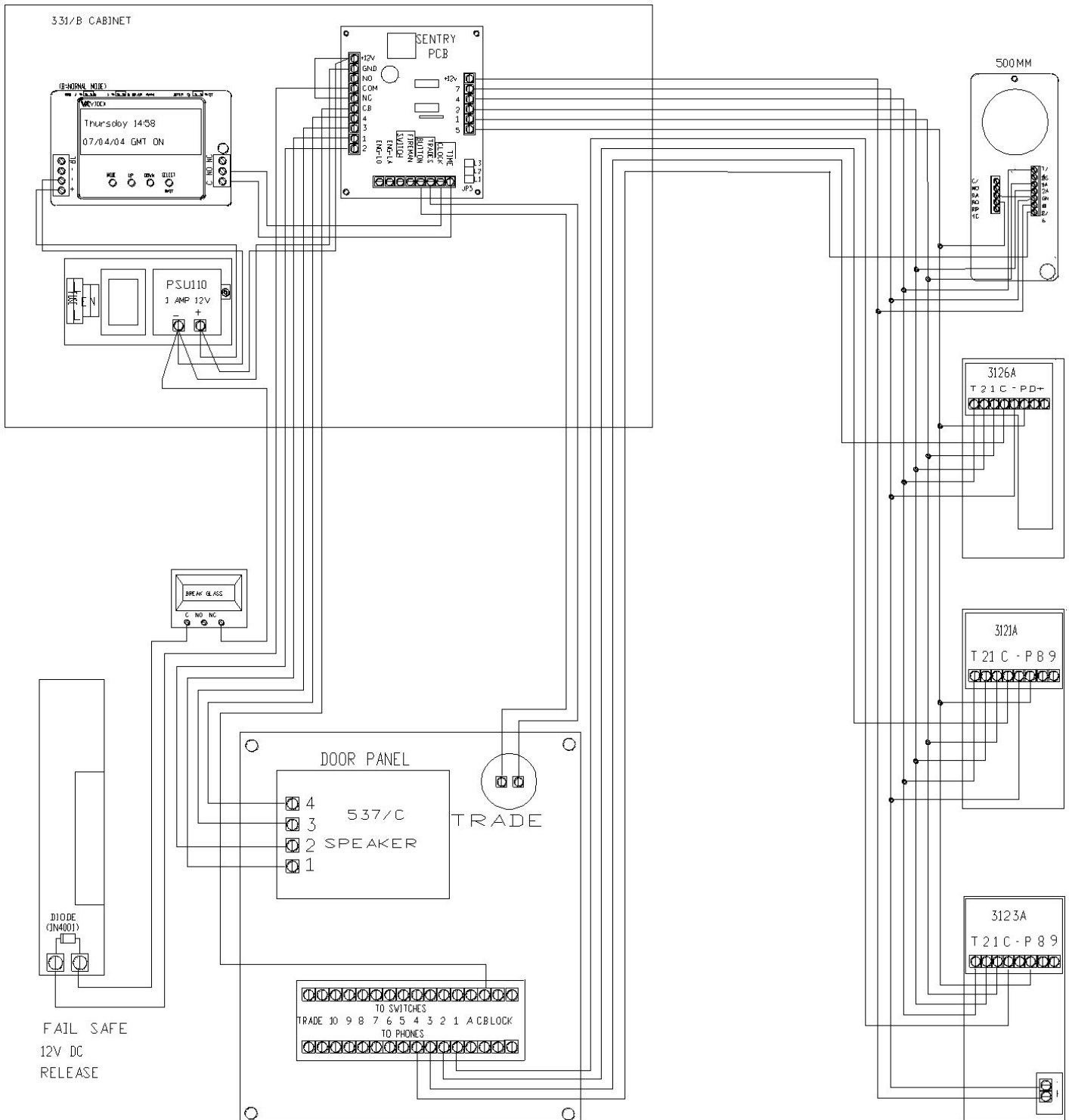

WIRING DIAGRAM

This diagram shows a single entrance vandal resistant door panel connected to multiple apartments with full isolation to prevent a single apartment compromising the whole system.

The lock release shown is fail secure. The SP35 door monitoring PCB is also shown along with a set of normally closed door contacts. This will be used to activate the door open LED on the telephone handsets.

The isolation cards each support four apartments. All the isolation cards can be mounted together in one location or separately on each landing.

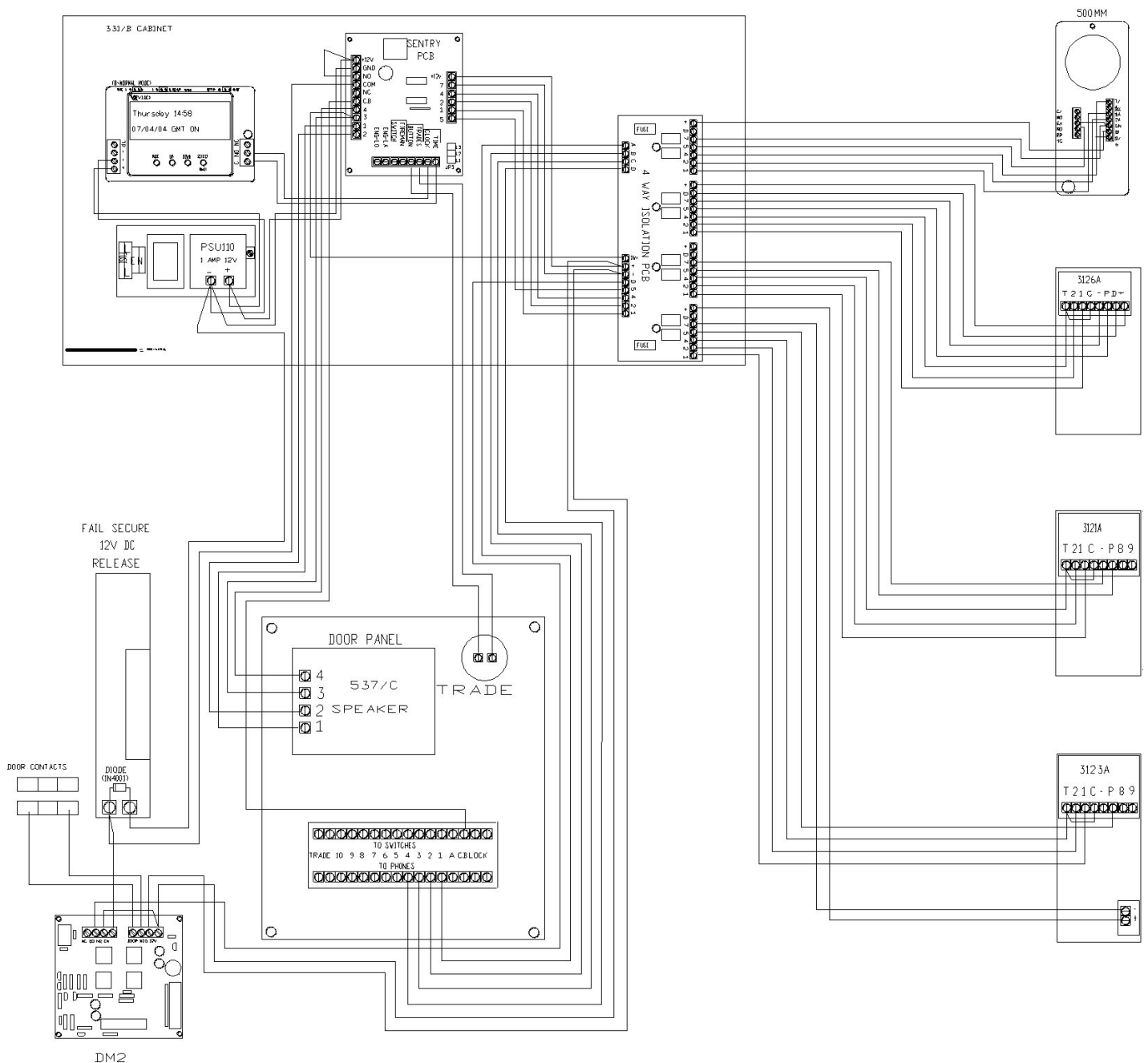

WIRING DIAGRAM

This diagram shows a single entrance video system with vandal resistant door panel connected to multiple apartments.

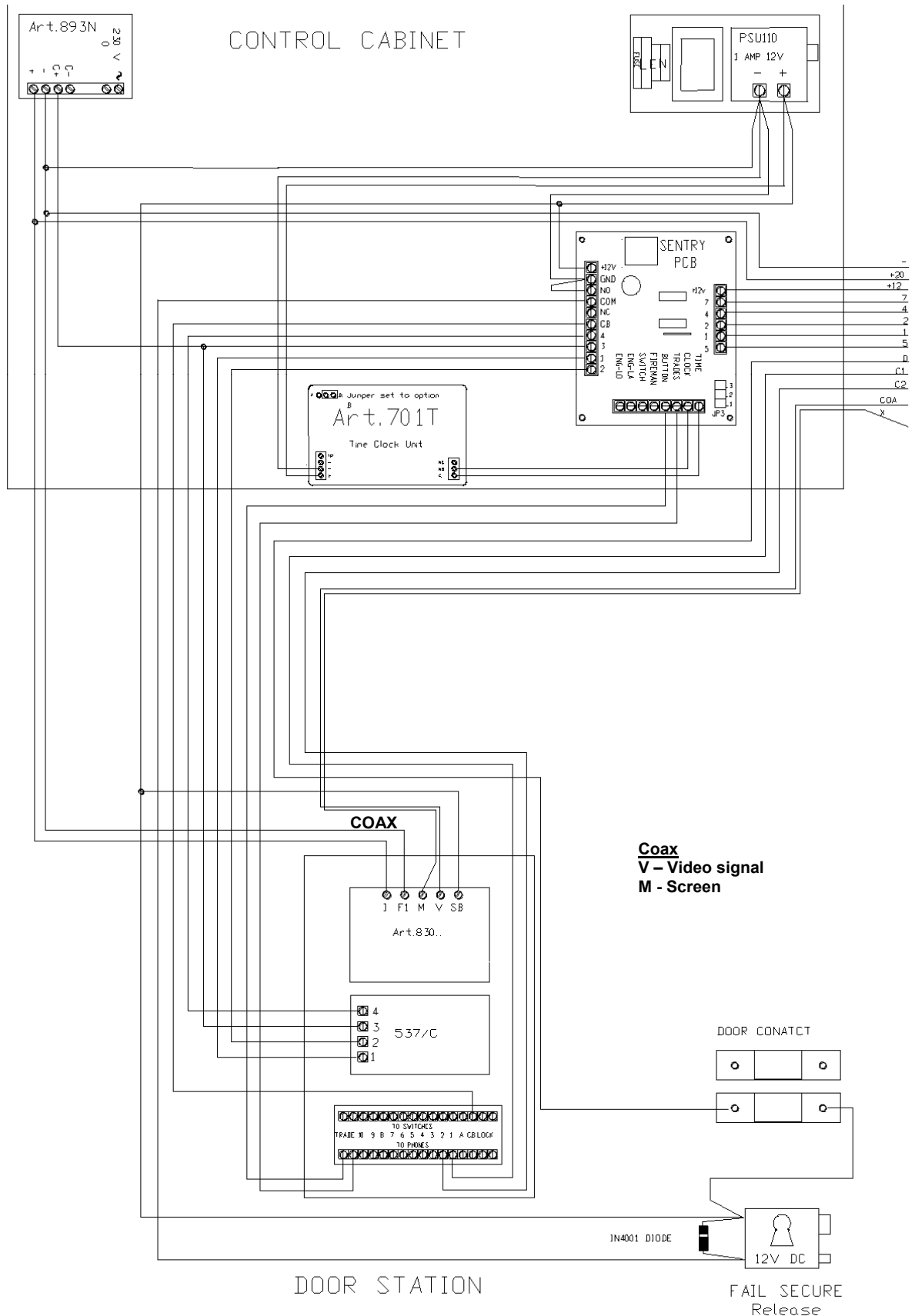

WIRING DIAGRAM

This diagram shows a single entrance apartment station system.

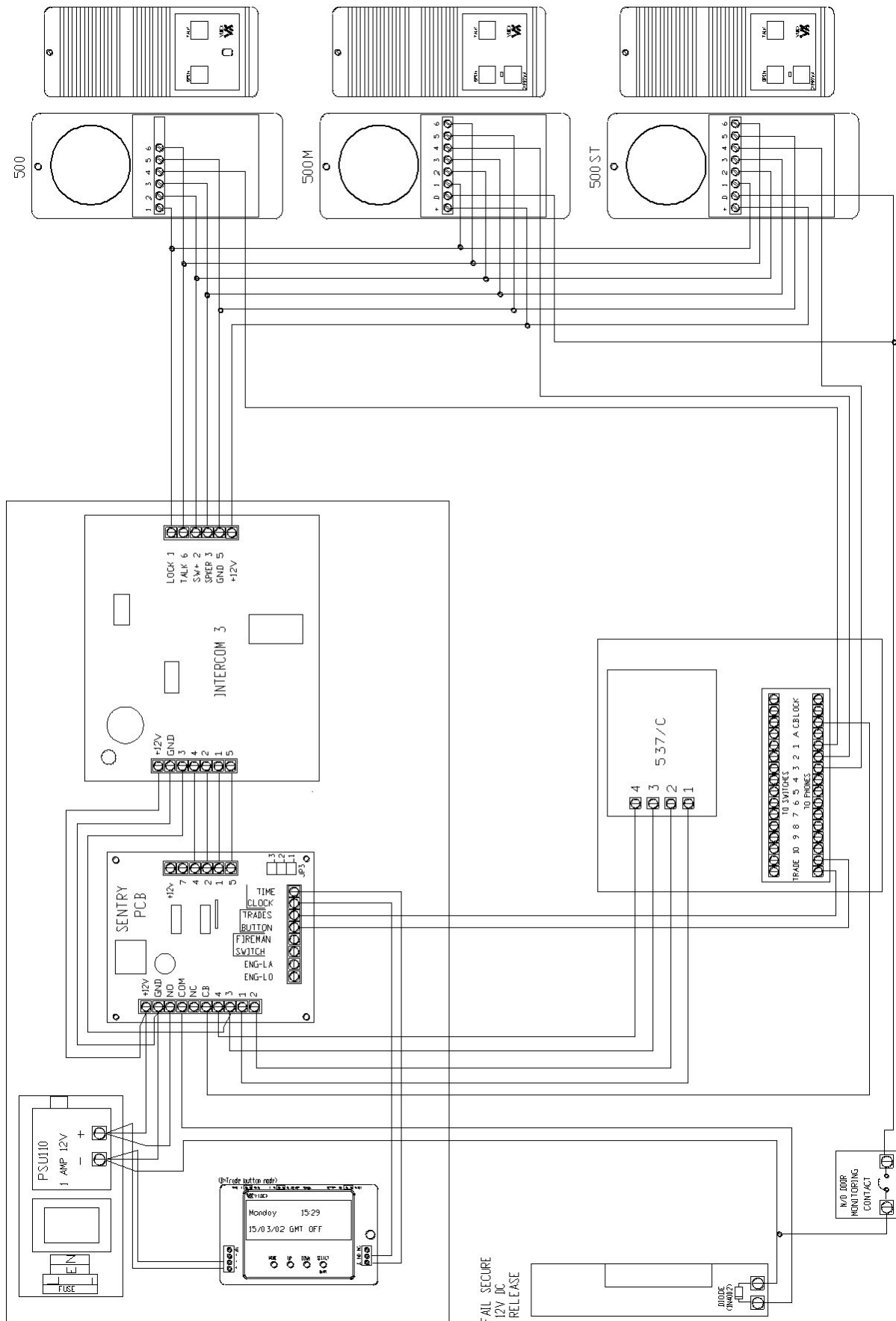

WIRING DIAGRAM

This diagram shows the ART.136 amplifier used in the door panel. (Remember to fit the 680R resistor across terminals 1&3 of the Sentry PCB)

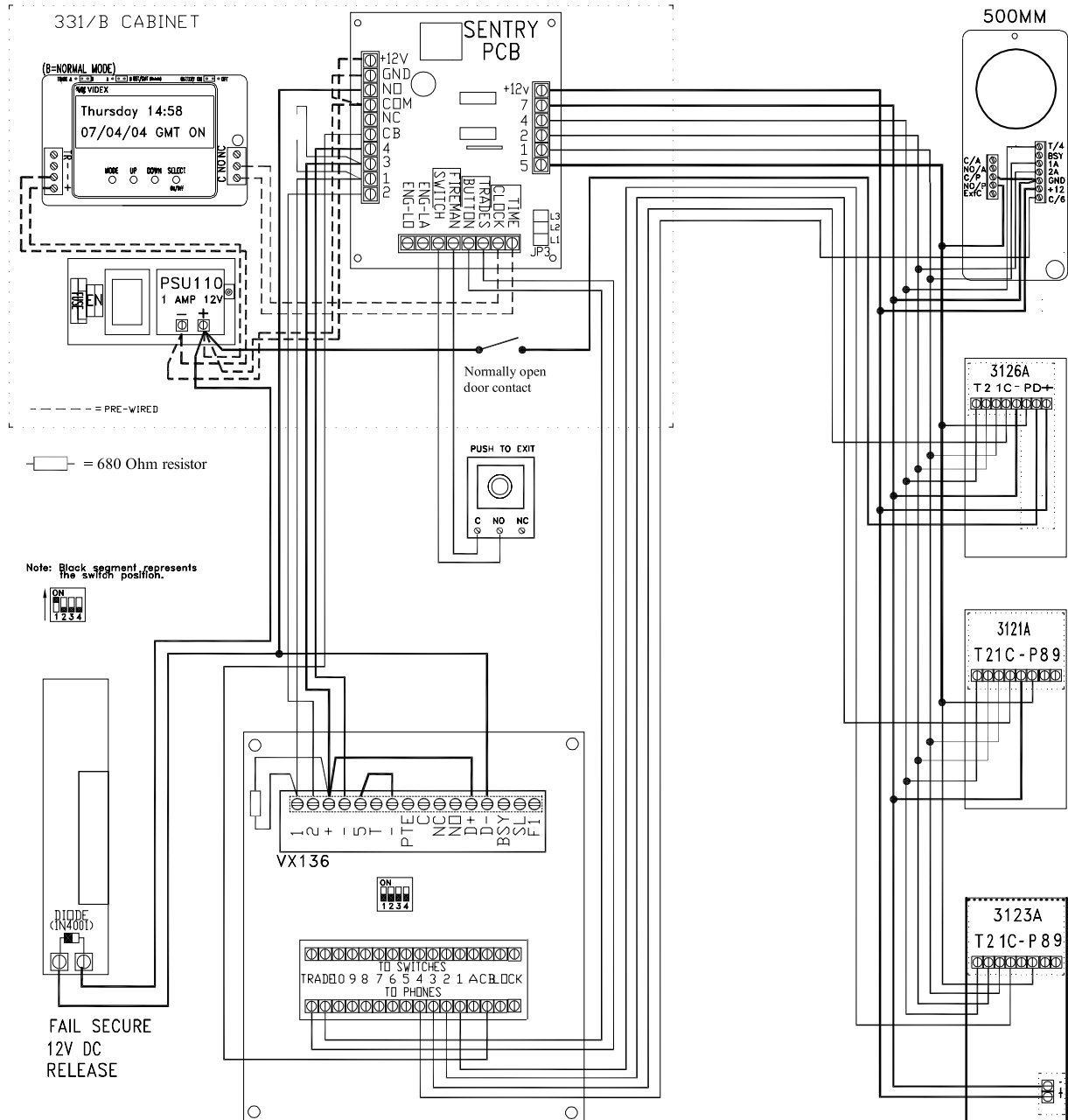

TROUBLE SHOOTING

When trouble shooting a large system, it will be easier to break the system down to a manageable size. The simplest way to do this is to remove all but one handset. Doing this, you can confirm the door panel and control cabinet are free from faults. Once this has been confirmed you can reconnect the handsets in small sets (Floor by floor), testing after each set to see if the fault has re-appeared.

SYMPTOM	TEST
No speech from door panel	Check terminal 2 on the amplifier for continuity back to the sentry PCB
	Check terminal 2 on the handset for continuity back to the sentry PCB
	During a call but before lifting the handset, check the voltage to the telephone on terminal 2 is 12Vdc. Trace this voltage from amplifier terminal 2 to the telephone.
	Check the voltage drops to approx. 1Vdc during a call after the handset is lifted. (If not try another telephone)
	If all else fails try another amplifier at the door station
No speech from handset	Check terminal 1 on the amplifier for continuity back to the sentry PCB
	Check terminal 1 on the handset for continuity back to the sentry PCB
	During a call but before lifting the handset, check the voltage to the telephone on terminal 1 is 12Vdc. Trace this voltage from amplifier terminal 1 to the telephone.
	Check the voltage drops to approx. 4Vdc during a call after the handset is lifted. (If not try another telephone)
	If all else fails try another amplifier at the door station
Handset beeps only once when called	Check the voltage across 3&4 on the door panel amplifier. During a call this should be 12Vdc (Supplied from the Sentry PCB)
Handset only rings for 1 second	Check terminal 1 going to the handset for continuity back to terminal 1 on the door station via the Sentry PCB.
Phone does not stop ring when handset is lifted.	Check terminal 2 on handset for continuity back to the Sentry PCB.
Lock will not operate from telephone	Check terminal P on the telephone for continuity back to the Sentry PCB.
	Check the voltage on terminal 5 of the handset. 5Vdc in standby dropping to 0V when the release button is pressed during a call.
Lock operates as soon as the handset is lifted.	Check for shorts across terminal 5 of the telephones and other cables.
	Check terminal 5 voltage. Should be 5Vdc when the button is not being pressed (5V is generated by the Sentry PCB).

Nothing happens when any call button is pressed	<p data-bbox="810 232 1198 264">Check power to the Sentry PCB.</p> <p data-bbox="810 309 1449 367">Check the CB line to the door panel. Should be 12Vdc.</p>
No call tone to telephone but speech and lock ok when handset is lifted	<p data-bbox="810 398 1449 456">Check terminal T on the telephone for continuity back to the Sentry PCB</p> <p data-bbox="810 472 1449 562">Check the call tone fuse on the Sentry PCB. (If it repeatedly blows then there is a short on the T line to the telephones)</p>
Hum on the speech lines	<p data-bbox="810 593 1449 651">Ensure all intercom cables do not run close to higher voltage cables</p> <p data-bbox="810 651 1273 683">Try another amplifier at the door panel.</p>

Northern Office

Videx Security Ltd
Unit 4-7 Chillingham Ind. Est.
Newcastle Upon Tyne
NE6 2XX
TEL 0870 300 1240
FAX 0191 224 5678

Southern Office

1 Osprey
Trinity Park
Trinity Way
London
E4 8TD
FAX 0208 523 5825

TECHNICAL SUPPORT

tech@videx-security.com
TEL 0191 224 3174
FAX 0191 224 4938
<http://www.videx-security.com>

